

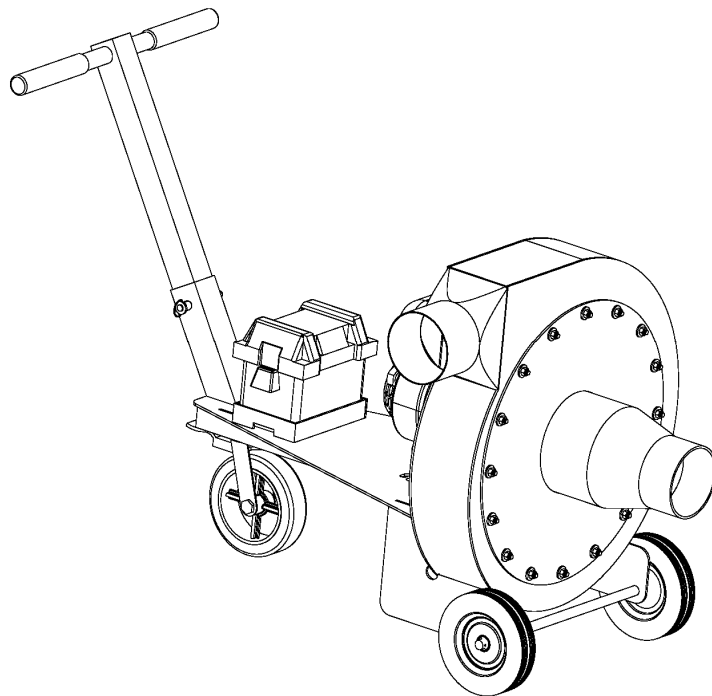

**INSULATION  
REMOVAL VACUUM  
MODEL #INSUL18  
INSTRUCTION MANUAL**



## RECEIVING YOUR INSULATION REMOVAL VACUUM

Immediately check the condition of your new Insulation Removal Vacuum as received. The machine was shipped in perfect condition and should arrive the same way. If there are any visible problems, mark them on the Bill Of Lading that the carrier has and call his office *before* the driver leaves your premises. As sympathetic as we are to any damages or shortages that occur in shipping, Nikro Industries, Inc. has no legal recourse with the shipping contractor for such claims; title to your machine was transferred to the carrier as soon as it left our dock. However, please let us know by phone and in writing about any problems so that we can assist you with immediate replacement parts or information.

## UNCRATING

Carefully remove all of the packing materials and check the parts against the Packing List. Your Insulation Removal Vacuum was test-run and shipped with all fluids at the proper levels. If there are any missing parts please contact Nikro Industries Inc.

Your insulation removal vacuum was shipped with the proper level of oil. Check the level now and add oil if needed.

## CONTENTS

**1 - #INSUL18 – 18 HP Insulation Removal Vacuum**

1 - #860454 – Fuel Tank

5 - #860866 – Disposable Collection Bags



## SAFETY

Safety is proudly built into every product manufactured by Nikro Industries, Inc. Carelessness and/or negligence are the usual causes for personnel injury and equipment failure. Safety is very important to everyone so we insist that all operators read and understand this manual.

1. Equipment is to be operated by trained qualified personnel only.
2. Always read and follow the operating and safety procedures.
3. Do not operate without all guards and safety equipment installed in the proper location and in working order.
4. Do not disable any safety features. They are there for your protection.
5. Always use qualified personnel when repairing or maintaining the equipment.
6. This equipment must be used only for the purpose for which it was intended. Any other use will void the warranty and could cause bodily injury to the operator and costly damage to the equipment.
7. If a malfunction should occur, turn the machine off immediately and correct the problem, before restarting the machine.
8. Do not leave the equipment unattended while it is running.
9. Do not wear loose clothing or jewelry when operating this equipment. A hat or a hair net should confine long hair.
10. Do not operate under the influence of alcohol or drugs.
11. Keep all people and property out of the possible discharge area of this machine to avoid objects that may puncture the collection bag. (See page 10 & 11)
12. Turn machine off immediately if excessive vibration or noise occurs.

## VACUUM SAFETY

1. Limit the operation only to those personnel trained in the proper use and operation of the machinery.
2. Never operate the machine without proper ventilation.
3. Keep all clothing and your body away from the inlet, discharge, and rotating equipment.
4. Obey all safety labels and instructions affixed to the machine.
5. Never run the machine speed faster than the factory settings.
6. Do not attempt to remove the bag or hoses until the engine has come to a complete stop.
7. The fan wheel assembly has been balanced at the factory. The fan wheel has become unbalanced if noises or vibrations are heard. The assembly is rotating at 3600 rpm; in an out-of-balance situation, the possibility of the wheel exploding in the housing is extremely great if allowed to continue. **The possibility of injury or death to the operator or any bystanders is very real.**

**If there are any questions as to the safe operation of this equipment, please do not hesitate to contact us at 1-800-875-6457.**

# SPECIFICATIONS

## **PURPOSE**

The Insulation Removal Vacuum is designed to safely and easily remove existing insulation.

## **SPECIFICATIONS:**

HEIGHT: 37 1/8"

WIDTH: 27 3/4"

DEPTH: 59 3/8"

WEIGHT: 330 LBS

## **FUEL REQUIREMENTS:**

The 18HP engine uses Regular Unleaded gasoline.

## **OIL TYPE:**

10W 30.

## SET UP

1. Install the handle and secure with pin.

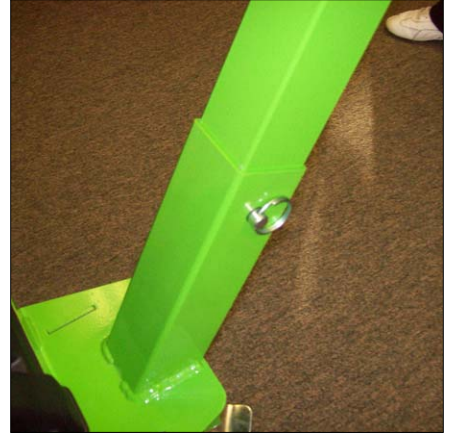
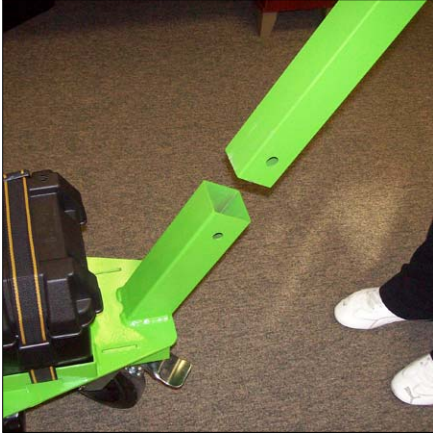

2. Place your Insulation Removal Vacuum on a level surface.



3. Apply the brake located on the swivel caster.



4. Position the bag clamp strap around the bag, open the neck of the collection bag (#860866) and pull it over the exhaust port of the vacuum (See Pic 1). Position the collection bag over and beyond the bag ring. Pull the end of the strap to tighten and secure the bag to the exhaust port. (See Pics 2&3) Position it so the filter bag will not be blown by the wind and come in contact with the exhaust system of the engine.



5. Attach the 6" x 25' (#860872) hose to the inlet of the Insulation Removal Vacuum by sliding the hose over the intake and securing it with a Adjustable Hose Clamp (#860291) by using a screwdriver or 5/16" socket. (See Pics 1,2,3)



6. Additional 6" x 25' hose (#860872) lengths may then be attached to the hose using 6" hose connectors (#860897) and clamps (#860291). Slide the hose connector into the end of the first hose and secure it with a hose clamp (#860291). Take another 6" hose (#860872) and slide it over the other end of the hose connector (#860867) and securely tighten it with a hose clamp (#860291).



7. Insert the 6" to 4" Hose Reducer into the last section of 6" x 25' hose (#860872). Secure the reducer to the 6" hose (#860872) by using a hose clamp (#860291) and tighten the clamp using a screwdriver or 5/16" socket.



8. Connect the 4" Hose (#860871) to the 6" to 4" hose reducer (#860868). Place a hose clamp (#860291) on this hose and by using a screwdriver or 5/16" socket, tighten the clamps securely.





9. Connect the 4' x 4" Pick-up tube (#860875) to the end of the 4" x 25' hose (#860871). Tighten the hose clamp (#860291) with a screwdriver or 5/16" socket to secure the hose to the pick-up tube



10. Connect the fuel line to the fuel tank. Take the engine fuel line hose with female quick connector and connect it to the male coupler located on the remote gas tank.



**DO NOT OVERFILL THE GAS TANK. ALLOW ROOM FOR EXPANSION OF THE FUEL. DO NOT LET THE FUEL LINE COME IN CONTACT WITH THE EXHAUST SYSTEM.**



## PRE START-UP

### **REMEMBER: SAFETY FIRST!!!!**

- Equipment is to be operated by trained qualified personnel only.
- **AT ALL TIMES KEEP YOUR HANDS, CLOTHING, ETC. AWAY FROM THE INLET AND DISCHARGE OF YOUR INSULATION REMOVAL VAC.**
- **Keep children and pets away from the machine while it is running.**
- When not using the **Insulation Removal Vacuum** move the throttle to the slow position.
- Your **Insulation Removal Vacuum** is a powerful vacuum and should be treated as such. Wooden boards, nails and other foreign materials are commonly found in insulation. There is always the possibility of these objects penetrating the filter bag. Be aware of the possible discharge area noted in diagram #1 and position the vacuum accordingly. If it is not possible to keep the area clear, then refer to page #11 for alternative discharging methods.

Diagram #1

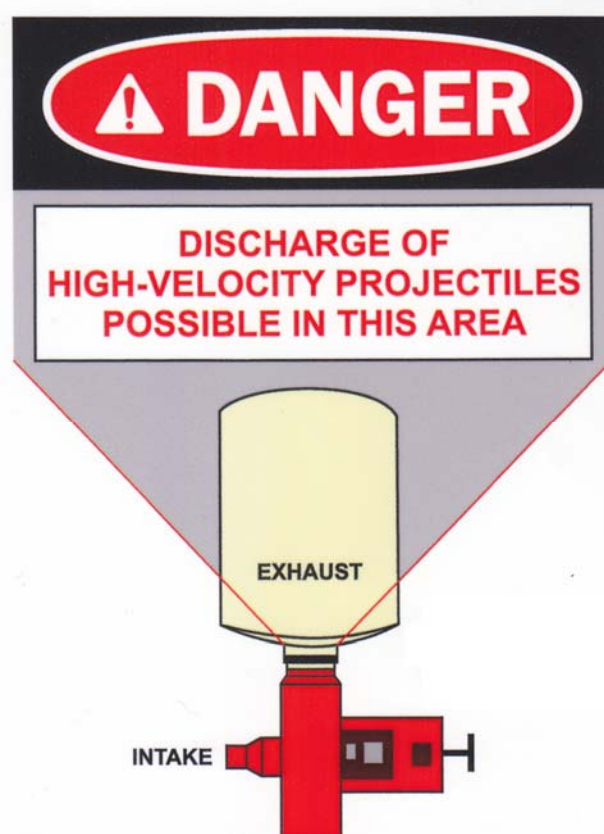

## ALTERNATIVE DISCHARGING

The following discharge option methods can be used especially when it is not possible to operate the unit with safe clearance of people and property on the exhaust discharge as illustrated in Diagram #1 (see page 10)

Alternative #1 – Connect a section of the 6" diameter vaculite hose (#860872) (maximum length 25', minimum 10') to the exhaust port of the unit.



Run the hose into a trash dumpster and connect a collection bag (#860866) to the end of the hose using adjustable hose clamp (#860291).



Before starting the engine, make sure that the collection bag is not twisted to assure it will inflate and fill properly. Place lid on trash dumpster or cover with a tarp.



## ENGINE STARTING

1. Place the throttle control midway between the slow and fast positions. Place the choke control into the on position.



2. Start the engine by activating the key switch. Release the switch as soon as the engine starts.

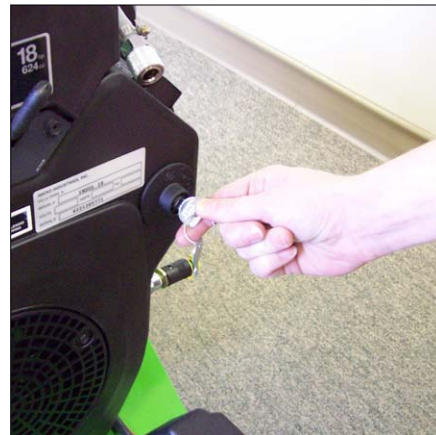

3. As the engine warms up slowly place the choke back to the off position and you may begin to move up the throttle.



Your Insulation Removal Vacuum is now ready to use.

## WET INSULATION PICK UP

If insulation is wet place a tarp underneath disposable bag. Due to the weight of wet insulation, the disposable bag can tear when moving. Lift the tarp with disposable bag on top for easy disposal.



## SHUT DOWN

1. Move the throttle to the slow position. Run the machine for approximately five (5) minutes.



2. Turn the engine off.

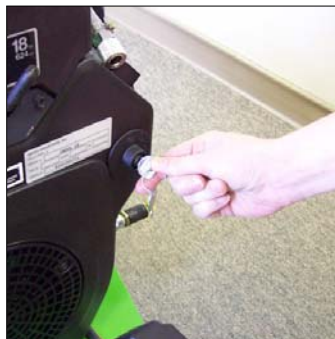

## SHUT DOWN CONTINUED

3. Disconnect the fuel line from the remote gas tank



4. Remove the collection bag.



5. Disconnect the hose.



**CAUTION!** Do not remove the hose or the bag until the **Insulation Removal Vacuum** has come to a complete stop.

## MAINTENANCE

1. ENGINE: Refer to the attached Kohler service manual for the engine servicing.
2. BATTERY: The 12 volt battery provided with your equipment is of the lead acid type. The battery cables should be checked daily for corrosion and tightness.
3. FAN HOUSING AND WHEEL: During the normal use of your **Insulation Removal Vacuum**, no maintenance is required on the fan wheel or housing.\*

\*If a problem, noise, or vibration should occur, stop the equipment immediately!! Contact the factory as soon as possible. Do not operate this equipment until it has been thoroughly checked by the factory or factory authorized representative.

---

The fan wheel assembly has been balanced at the factory. The fan wheel has become unbalanced if noises or vibrations are heard. The assembly is rotating at 3600 rpm; in an out-of-balance situation, the possibility of the wheel exploding in the housing is extremely great if allowed to continue. **The possibility of injury or death to the operator or any bystanders is very real.**

---

Contact RMA – Nikro Industries – 800-875-6457

\* Do not replace the factory fan with any other fan other than the factory-approved replacement.

## TROUBLESHOOTING

**ENGINE:** Refer to the attached owners manual for engine servicing and troubleshooting. Contact a Kohler authorized dealer.

**NO SUCTION FROM THE END OF THE HOSE:**

1. Stop engine and remove key



2. Check hoses for blockage or loose connections



3. Check fan inlet for blockage
4. Check discharge for blockage



5. Inspect fan interior for blockage





# PARTS LIST

PC NO	PART NO	PART NAME	QTY
1	861541	BLOWER KIT 7GA HRS CS-B 100B	1
2	862027	INSUL INTAKE	1
3	861658	BATTERY BOX	1
4	861675	BATTERY 12V	1
5	861778	3/8" FLAT WASHER	20
6	861773	NUT HEX ZN 3/8-16	24
7	862116	18HP KOHLER ENGINE	1
8	862133	FLAT WAHER 2" X 13/16	4
9	861633	WHEEL, 8" PNEUMATIC	2
10	860487	HANDLE	1
11	861652	FOAM GRIPS	2
12	861653	LOCKING PIN	1
13	862134	COTTER PIN / AXEL	2
14	861859	REMOTE OIL FILTER	1
15	861513	WASHER 5/16"	6
16	861811	5/16-18 X 1" HEX HEAD SCREW	2
17	861512	WASHER 5/16" FLAT	2
18	861768	HEX NUT 5/16" - 18 ZN	2
19	861543	RADIAL BLOWER WHEEL	1
20	861634	CASTER 8" LOCKING	1
21	861747	3/8 - 16 X 1" HEX BOLT	4
22	861070	3/8 LOCK WASHER	8
23	862138	3/8 - 16 X 2" HEX BOLT	4
24	862137	5/16 - 24 X 3/4" HEX BOLT	4

